

Repair Parts List

MODEL NUMBER

A209

WASHER

When requesting service or ordering parts, always provide the following information:

- Product Type
- Part Number
- Model Number
- Part Description

MAYTAG®

©2005 Maytag Services

Section: CONTROL PANEL, TIMER & SWITCHES

Model: A209

MODELS A209-A209S

CONTROL PANEL, TIMER & SWITCHES

A209

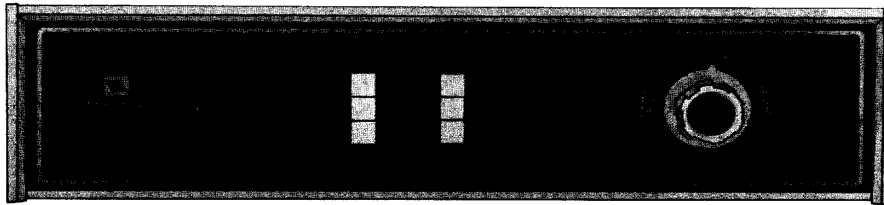

A209S

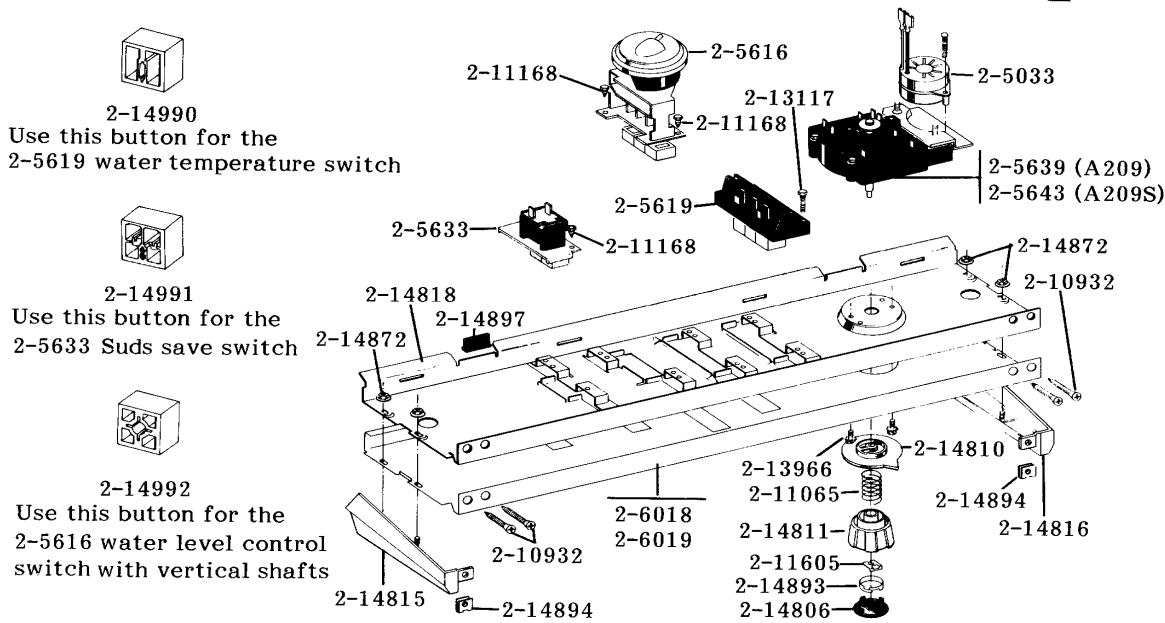
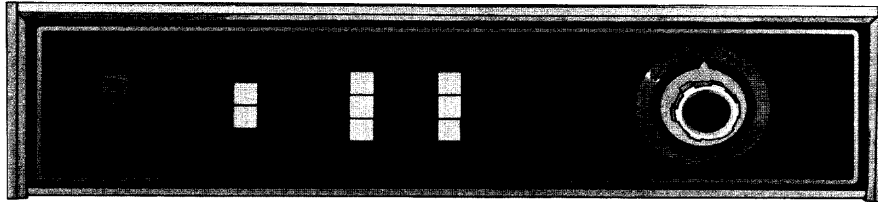

2-14990
Use this button for the 2-5619 water temperature switch

2-14991
Use this button for the 2-5633 Suds save switch

2-14992
Use this button for the 2-5616 water level control switch with vertical shafts

- | | | | |
|---------|-----------------------------------------------------------------------------------|---------|------------------------------------------------------------------------------|
| 2-5033 | Timer motor for 2-5639 and 2-5643 timers | 2-13117 | Screw - water temperature switch and fabric switch to back-up plate - 2 used |
| 2-5616 | Water level control switch | 2-13966 | Screw - timer to back-up plate - 2 used |
| 2-5619 | Water temperature switch | 2-14806 | Cap for timer knob |
| 2-5633 | Suds Save switch - A209S | 2-14810 | Timer dial indicator |
| 2-5639 | Timer for A209 | 2-14811 | Knob for timer |
| 2-5643 | Timer for A209S - Suds Save model | 2-14815 | End cap for control panel - L.H. |
| 2-6018 | Control panel for A209 | 2-14816 | End cap for control panel - R.H. |
| 2-6019 | Control panel for A209S - Suds Save model | 2-14818 | Back-up plate |
| 2-10932 | Screw - control panel to console and end caps to support plates - 4 used | 2-14872 | Nut - end caps to back-up plate - 4 used |
| 2-11065 | Spring for timer knob | 2-14893 | Detent ring for timer knob cap |
| 2-11168 | Screw - water level control switch and Suds Save switch to back-up plate - 2 used | 2-14894 | Fastener - end caps to back-up plate - 2 used |
| 2-11605 | Retaining clip - knob to timer | 2-14897 | Cushion pad for control panel - 2 used |

Section: CONTROL PANEL, TIMER & SWITCHES

No.	Part No.	Description	Series	Qty
1	205033	TIMER MOTOR 120-60 Note: MOTOR, TIMER 120-60	00	1
2	205616	WATER LEVEL CONTROL SWITCH Note: SWITCH, WATER LEVEL	00	1
3	N 205619	WATER TEMPERATURE SWITCH Note: SWITCH, TEMPERATURE	00	1
5	205639	TIMER	00	1
7	N 206018	CONTROL PANEL Note: PANEL, CONTROL	00	1
9	210932	SCREW, #8 X 9/16 CTSK Note: SCREW, PANEL AND END CAP	00	1
10	211065	SPRING, TIMER KNOB	00	1
11	211168	SCREW, #8 X 5/16 INCH	00	1
12	211605	RETAINER, TIMER KNOB	00	1
13	213117	SCREW-TEMP. SWITCH TO PANEL Note: SCREW, TEMPERATURE SWITCH	00	1
14	213966	SCREW-TIMER TO CONTROL PANE Note: SCREW, TIMER	00	1
15	214806	CAP FOR TIMER KNOB Note: CAP, TIMER KNOB	00	1
16	214810	TIMER DIAL INDICATOR Note: INDICATOR, TIMER DIAL	00	1
17	214811	KNOB FOR TIMER Note: KNOB, TIMER	00	1
18	N 214815	END CAP F/CONTROL PANEL-LH Note: CAP, END (LH)	00	1
19	214816	END CAP F/CONTROL PANEL-RH Note: (RH)	00	1
20	214818	BACK UP PLATE Note: PLATE, BACK UP	00	1
21	214872	PALNUT, END CAP	00	1
22	N 214893	DETENT RING F/TIMER KNOB CA Note: DETENT RING, TIMER KNOB CAP	00	1
23	214894	FASTENER, END CAP	00	1
24	N 214897	PAD, CONTROL PANEL	00	1

*Color Code (-)=Not Shown #=Series, Serial Prefix or Run No., N=Not Available

Section: TOP COVER, CONSOLE & LID SWITCH

Model: A209

ALL MODELS **TOP COVER, CONSOLE, LID & SWITCH**

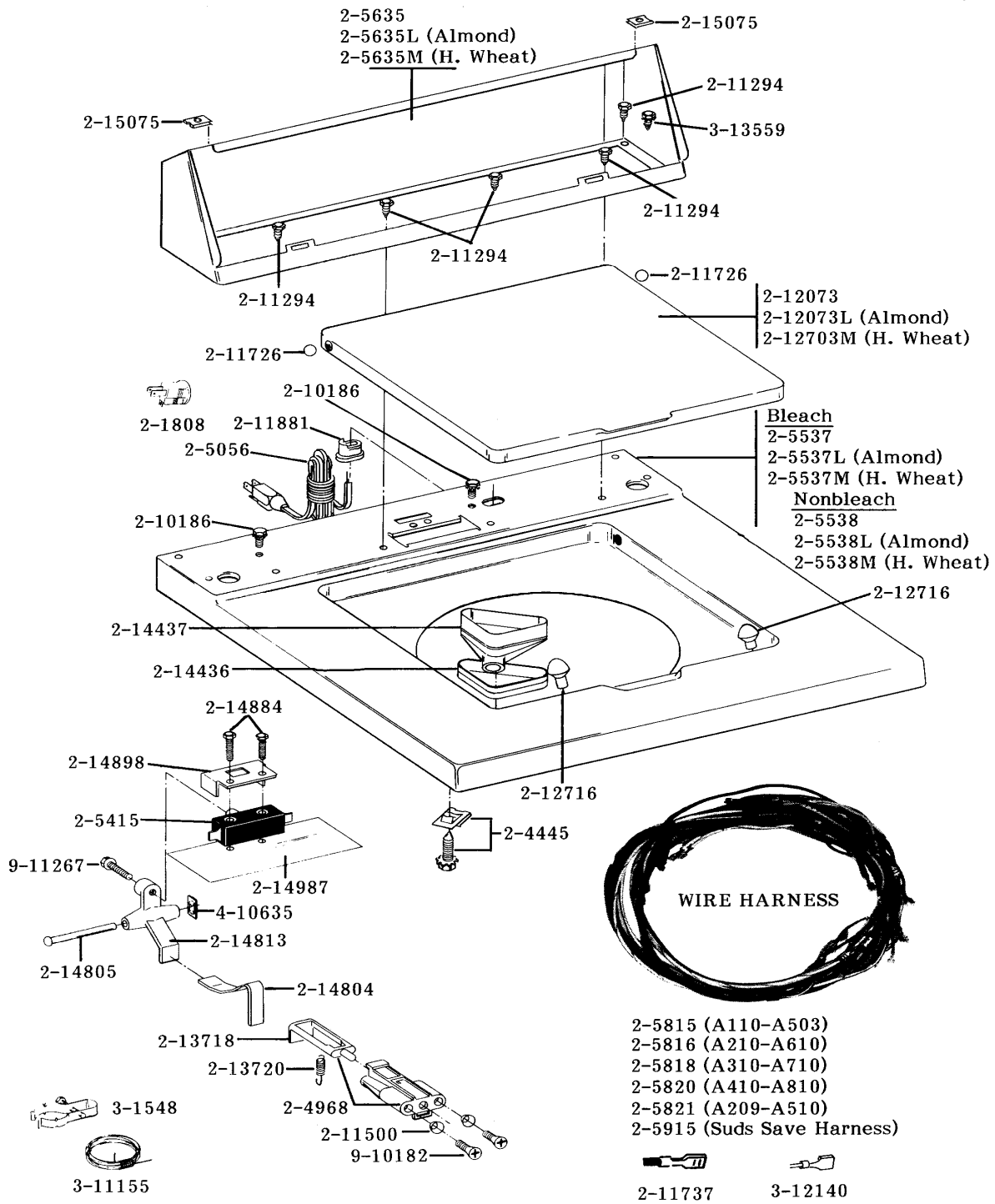

58A13

Section: TOP COVER, CONSOLE & LID SWITCH

No.	Part No.	Description	Series	Qty
1	205997	NON-BLEACH CONVERSION KIT	00	1
2	N 201808	CONVERTER	00	1
3	204445	SCREW & FASTENER ASY. Note: SCREW & FASTENER ASSEMBLY	00	1
4	204968	PLUNGER & BRACKET ASSEMBLY	00	1
5	205056	CORD, POWER	00	1
6	205415	SWITCH, LID (W/O TUB LIGHT)	00	1
7	N 205538	TOP COVER-WHITE Note: TOP COVER (WHT)	00	1
9	N 205635	CONSOLE (WHT)	00	1
11	N 205821	MAIN WIRE HARNESS Note: HARNESS, MAIN WIRE	00	1
13	210186	SCREW, GROUND WIRE TO BASE--NA	00	1
14	211294	SCREW	00	1
15	211500	WASHER,BRACKE TO TOP COVER Note: WASHER, BRACKET	00	1
16	211726	HINGE, BALL	00	1
17	211737	WIRE CONNECTOR Note: CONNECTOR, WIRE	00	1
18	211881	GROMMET, CORD	00	1
19	212073	LID-WHITE Note: LID (WHT)	00	1
21	212716	BUMPER, LID	00	1
22	213718	LID SWITCH PLUNGER Note: PLUNGER, LID SWITCH	00	1
23	213720	SPRING	00	1
24	214804	UNBALANCE LEVER Note: LEVER, UNBALANCE	00	1
25	214805	PIN FOR UNBALANCE LEVER Note: PIN, UNBALANCE LEVER	00	1
26	214813	LEVER FOR LID SWITCH Note: LEVER, LID SWITCH	00	1
27	214884	SCREW - LID SWITCH Note: SCREW, LID SWITCH	00	1
28	214898	COVER FOR LID SWITCH Note: COVER, LID SWITCH	00	1
29	214987	MOISTURE BARRIER FOR SWITCH Note: MOISTURE BARRIER, SWITCH	00	1
30	215075	FASTENER,CNTRL PNL TO CONSOLE Note: FASTENER, CONTROL PANEL	00	1
31	301548	CLAMP, GROUND (W/SCREW)	00	1
32	311155	GROUND WIRE Note: WIRE, GROUND	00	1
33	312140	WIRE CONNECTOR Note: CONNECTOR, WIRE	00	1
34	313559	SCREW	00	1
35	410635	FASTENER	00	1
36	910182	SCREW	00	1
37	911267	SCREW, PUMP COVER	00	1

*Color Code (-)=Not Shown #=Series, Serial Prefix or Run No., N=Not Available

Section: CBNT,WATER INJ & VALVE,HOSES & FRT PANEL

Model: A209

ALL MODELS

CABINET, WATER INJECTION, WATER VALVE, HOSES & FRONT PANEL

ACCESSORY HOSES

- 2-5828 4 ft. (1.22m) Straight Ends
- 2-672 5 ft. (1.51m) 90° Elbow
- 2-688 6 ft. (1.82m) 90° Elbow
- 2-681 10 ft. (3.04m) 90° Elbow
- 2-2861 Box of (25) 5 ft. straight end hoses, (25) gaskets, (25) screens

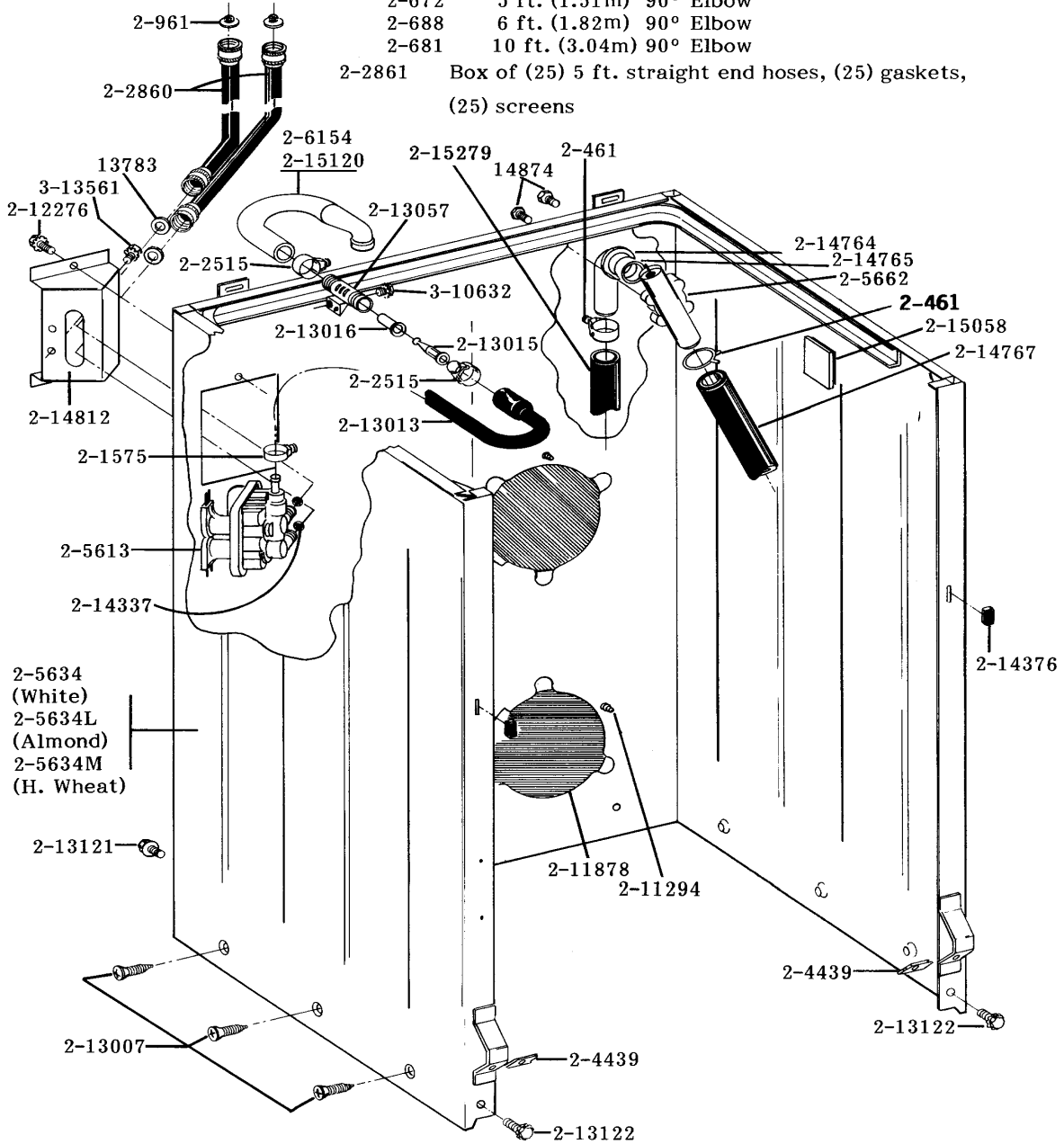

Section: CBNT,WATER INJ & VALVE,HOSES & FRT P

No.	Part No.	Description	Series	Qty
1	Y013783	GASKET, INLET HOSE Note: WASHER, INLET HOSE	00	1
2	Y014874	SCREW	00	1
3	200461	HOSE CLAMP - 1-5/8 INCH Note: CLAMP, HOSE 1-5/8 INCH	00	1
4	200672	INLET HOSE ASSY. Note: INLET HOSE ASSEMBLY	00	1
5	200681	INLET HOSE, HOT 10 FT. Note: HOSE, INLET HOT 10 FT.	00	1
6	200688	INLET HOSE, HOT 6 FT. Note: HOSE, INLET HOT 6 FT.	00	1
7	200832	CAPACITOR	00	1
8	200961	SCREEN WASHER, INLET HOSE	00	1
9	201575	HOSE CLAMP Note: CLAMP, HOSE	00	1
10	202515	HOSE CLAMP - 1-1/16 INCH Note: CLAMP, HOSE 1-1/16 INCH	00	1
11	202860	INLET HOSE ASSY. Note: INLET HOSE ASSEMBLY	00	1
12	202861	CARTON OF 25 HOSE, 5'	00	1
13	203237	#17 WIRE WITH TERMINAL	00	1
14	204439	SCREW & FSTNER ASSY(FRT.PANEL) Note: SCREW & FSTNER ASSM(FRT.PANEL)	00	1
15	205613	WATER VALVE Note: VALVE, WATER	00	1
16	N 205634	CABINET-WHITE Note: CABINET (WHT)	00	1
19	205662	SIPHON BREAK HOUSING Note: HOUSING, SIPHON BREAK	00	1
20	205828	HOSE, INLET ASSY. Note: HOSE, INLET ASSEMBLY	00	1
21	206103	CAPACITOR KIT	00	1
22	206154	INJECTOR TUBE WITH SEAL Note: TUBE, INJECTOR (W/SEAL)	00	1
23	211149	CLIP, CAPACITOR	00	1
24	211294	SCREW	00	1
25	N 211878	PLATE, ACCESS	00	1
26	212276	SCREW	00	1
27	212982	FASTENER, PANEL	00	1
28	212998	FRONT PANEL-WHITE Note: PANEL, FRONT (WHT)	00	1
30	213007	SCREW, CABINET	00	1
31	213013	HOSE, INJECTOR Note: HOSE, INJECTOR	00	1
32	213015	INJECTOR NOZZLE Note: NOZZLE, INJECTOR	00	1
33	213016	VALVE FOR INJECTOR SUB Note: VALVE, INJECTOR	00	1
34	213057	SLEEVE FOR INJECTOR Note: SLEEVE, INJECTOR	00	1
35	213121	SCREW	00	1
36	213122	SCREW,CBNT.TO FRNT OF BASE--NA Note: SCREW, CABINET	00	1
37	213846	GUARD, BELT	00	1
38	214337	SCREEN, VALVE	00	1
39	214376	SPACER, FRONT PANEL	00	1
40	214764	SIPHON BREAK ELBOW Note: ELBOW, SIPHON BREAK	00	1
41	214765	GASKET, SIPHON BREAK	00	1
42	214767	HOSE,PUMP TO SIPHON BREAK Note: HOSE, PUMP TO SIPHON BREAK	00	1
43	214768	DRAIN HOSE, 4 FOOT Note: HOSE, DRAIN 4 FOOT	00	1
44	214812	BRACKET,WATER VALVE Note: BRACKET, WATER VALVE	00	1
45	200461	HOSE CLAMP - 1-5/8 INCH Note: CLAMP, HOSE 1-5/8 INCH	00	1
46	215058	PAD, CABINET BUMPER	00	1
47	215120	SEAL FOR INJECTOR TUBE Note: SEAL, INJECTOR TUBE	00	1
48	310632	SCREW	00	1
49	N 313561	SCREW----NA	00	1

*Color Code (-)=Not Shown #=Series, Serial Prefix or Run No., N=Not Available

Section: TUB, AGITATOR, MOUNTING STEM & SEAL

Model: A209

ALL MODELS TUBS, AGITATORS, MOUNTING STEM & SEALS

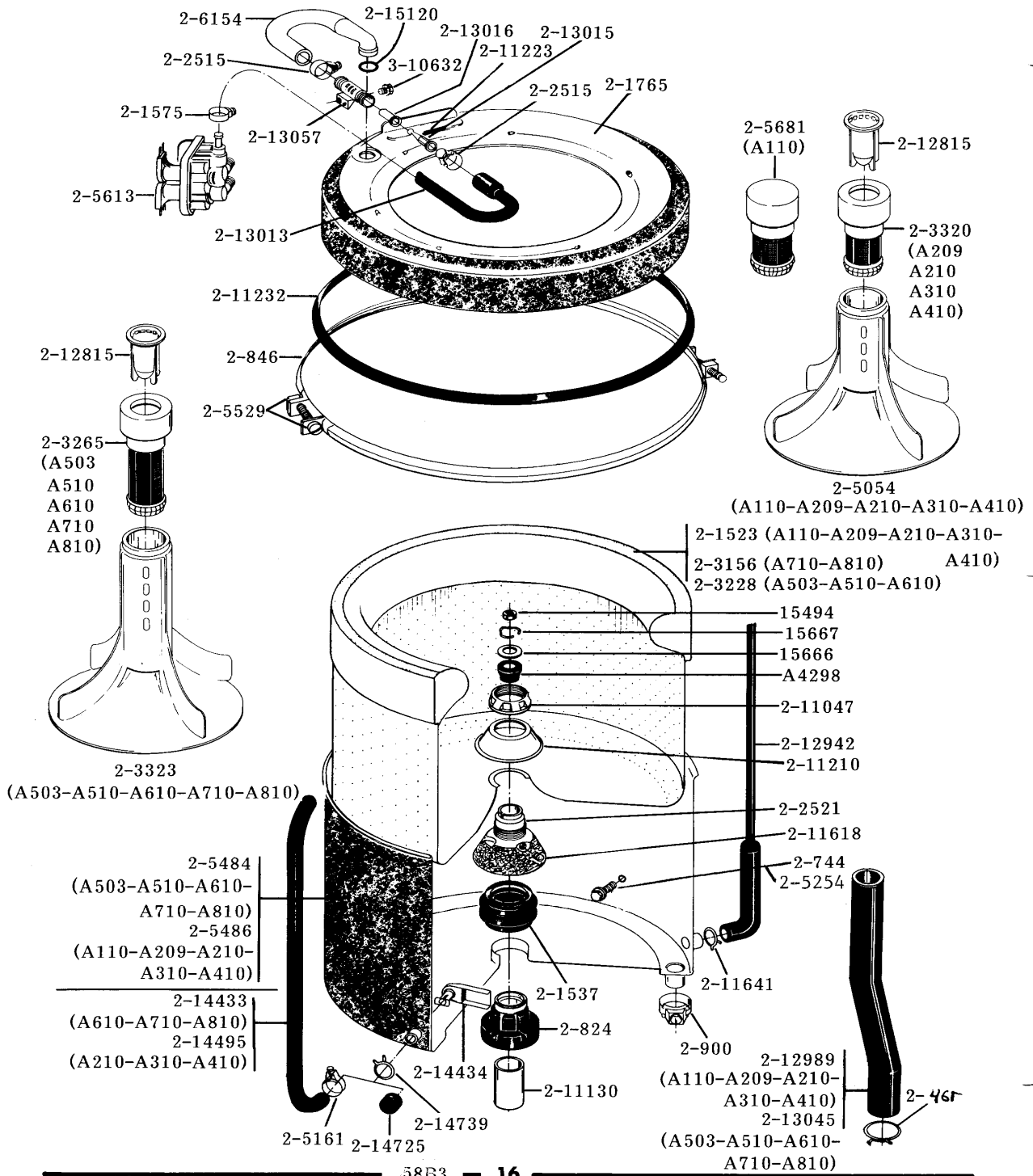

Section: TUB, AGITATOR, MOUNTING STEM & SEAL

No.	Part No.	Description	Series	Qty
1	N A04298	SEAL, AGITATOR DRIVE SHAFT	00	1
2	Y015494	STOP RING-AGITATOR SHAFT	00	1
3	015666	WASHER,RETAINING(CENTER SEAL)- Note: WASHER, RETAINING(CENTER SEAL)	00	1
4	Y015667	RETAINING RING	00	1
5	Y054867	WASHER, LOCK	00	1
6	200744	BOLT & GASKET ASSY.(SHORT) Note: BOLT & GASKET ASSM.(SHORT)	00	1
7	200824	BEARING, TUB	00	1
8	200846	CLAMP - TUB COVER Note: CLAMP, TUB COVER	00	1
9	200900	CLAMP, SPRAY ARM HOSE	00	1
10	N 201523	INNER TUB Note: TUB, INNER	00	1
11	201537	SEAL AND SPRING	00	1
12	201575	HOSE CLAMP Note: CLAMP, HOSE	00	1
13	201765	TUB COVER Note: COVER, TUB	00	1
14	202515	HOSE CLAMP - 1-1/16 INCH Note: CLAMP, HOSE 1-1/16 INCH	00	1
15	202521	MOUNTING STEM Note: STEM, MOUNTING	00	1
16	203320	LINT FILTER - DISPENSER Note: FILTER, LINT	00	1
17	204012	MOUNTING STEM REPAIR KIT	00	1
18	204013	TUB BEARING REPAIR KIT	00	1
19	205054	AGITATOR	00	1
20	205161	CLAMP - 15/16"	00	1
21	205486	TUB, OUTER	00	1
22	205529	NUT & BOLT KIT FOR TUB CLAM	00	1
23	205613	WATER VALVE Note: VALVE, WATER	00	1
24	206154	INJECTOR TUBE WITH SEAL Note: TUBE, INJECTOR (WITH SEAL)	00	1
25	211047	NUT, CLAMPING (INNER TUB)	00	1
26	211100	WASHER, CUSHION	00	1
27	211130	LINER, TUB BEARING	00	1
28	211210	WASHER,CLAMPING NUT(STAINLESS)	00	1
29	211223	UNBALANCE BUMPER Note: BUMPER, UNBALANCE	00	1
30	211232	SEAL	00	1
31	211618	SET SCREW, MTG. STEM Note: SET SCREW, MOUNTING STEM	00	1
32	211641	CLAMP, 1-1/16"	00	1
33	212815	DISPENSER CUP Note: CUP, DISPENSOR	00	1
34	212942	AIR DOME AND TUBE	00	1
35	Y212989	HOSE, OUTER TUB TO PUMP	00	1
36	213013	HOSE, INJECTOR Note: HOSE, INJECTOR	00	1
37	213015	INJECTOR NOZZLE Note: NOZZLE, INJECTOR	00	1
38	213016	VALVE FOR INJECTOR SUB Note: VALVE, INJECTOR	00	1
39	213057	SLEEVE FOR INJECTOR Note: SLEEVE, INJECTOR	00	1
40	214725	CAP FOR SPOUT-OUTER TUB Note: CAP, SPOUT-OUTER TUB	00	1
41	214739	SPRING HOSE CLAMP Note: CLAMP, SPRING HOSE	00	1
42	200461	HOSE CLAMP - 1-5/8 INCH Note: CLAMP, HOSE 1-5/8 INCH	00	1
43	215120	SEAL FOR INJECTOR TUBE Note: SEAL, INJECTOR TUBE	00	1
44	310632	SCREW	00	1

*Color Code (-)=Not Shown #=Series, Serial Prefix or Run No., N=Not Available

Section: TRANSMISSIONS

Model: A209

ALL MODELS **TRANSMISSIONS**

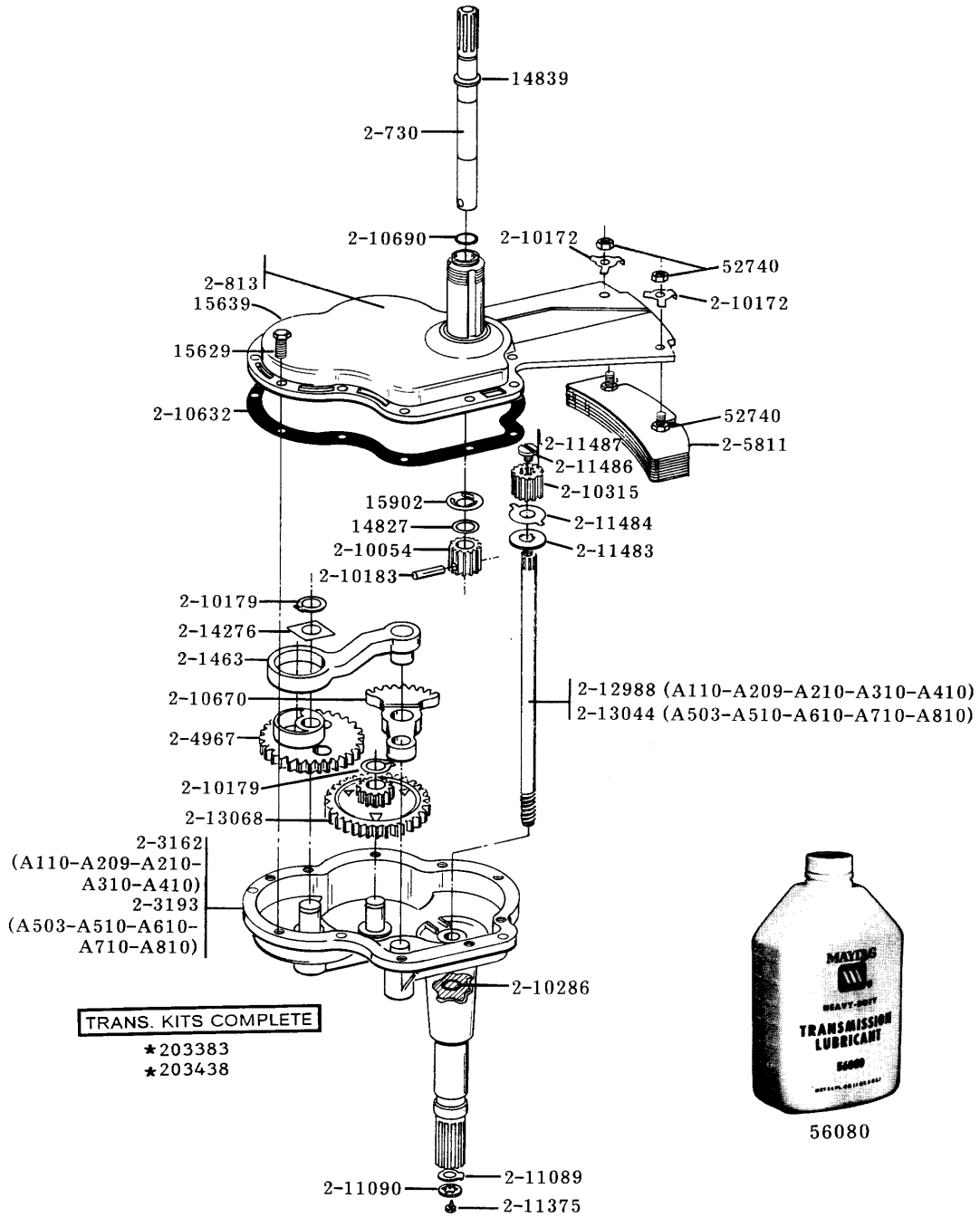

*Transmission Complete-Includes Orb. Trans., Lint Filter, Agitator W/Lock Screw, Dispensing Cup & Instructions

Section: TRANSMISSIONS

No.	Part No.	Description	Series	Qty
1	Y014827	WASHER-CENTER SHAFT Note: WASHER, CENTER SHAFT	00	1
2	014839	COLLAR-DRIVE SHAFT Note: COLLAR, DRIVE SHAFT	00	1
3	Y015629	BOLT, GRINDING CHAMBER-DRAI Note: BOLT, GRINDING CHAMBER	00	1
4	N 015639	DOWEL PIN Note: PIN, DOWEL	00	1
5	Y015902	SPRING FOR AGITATOR Note: SPRING, AGITATOR	00	1
6	Y052740	NUT	00	1
7	056080	TRANS LUBE - AUTO, 34 OZ.	00	1
8	200730	AGITATOR SHAFT Note: SHAFT, AGITATOR	00	1
9	N 200813	GEAR CASE COVER ASSEMBLY	00	1
10	N 201463	PITMAN WITH WRIST PIN	00	1
11	N 203162	GEAR HOUSING W/STUDS & TUBE	00	1
12	203383	TRANS & CENTER ASSM. REG TU	00	1
13	204967	GEAR KIT-POWER FIN AGITATOR	00	1
14	N 205811	COUNTERWEIGHT	00	1
15	210054	PINION	00	1
16	N 210172	LOCK WASHER Note: WASHER, LOCK	00	1
17	N 210179	RETAINING RING Note: RING, RETAINING	00	1
18	210183	GROOV-PIN, 1/4 X 1-1/4	00	1
19	210286	SEAL	00	1
20	210315	PINION	00	1
21	210632	GASKET	00	1
22	N 210670	SEGMENT	00	1
23	210690	SEAL, RUBBER	00	1
24	211089	LUG, STOP	00	1
25	211090	WASHER, LOCK	00	1
26	211375	SCREW,STOP LUG(CENTER SHAFT)	00	1
27	211483	WASHER, SPLINED	00	1
28	211484	LUG WASHER Note: WASHER, LUG	00	1
29	211486	SCREW, 3/8-16 X 1/2 INCH	00	1
30	N 211487	GROOV-PIN	00	1
31	212988	CENTER SHAFT Note: SHAFT, CENTER	00	1
32	213068	INTERMEDIATE GEAR Note: GEAR, INTERMEDIATE	00	1
33	N 214276	WASHER FOR GEARS Note: WASHER, GEARS	00	1

*Color Code (-)=Not Shown #=Series, Serial Prefix or Run No., N=Not Available

Section: BASE, PUMP, MOTOR & COMPONENTS

Model: A209

ALL MODELS

BASE, PUMP, MOTOR & COMPONENTS

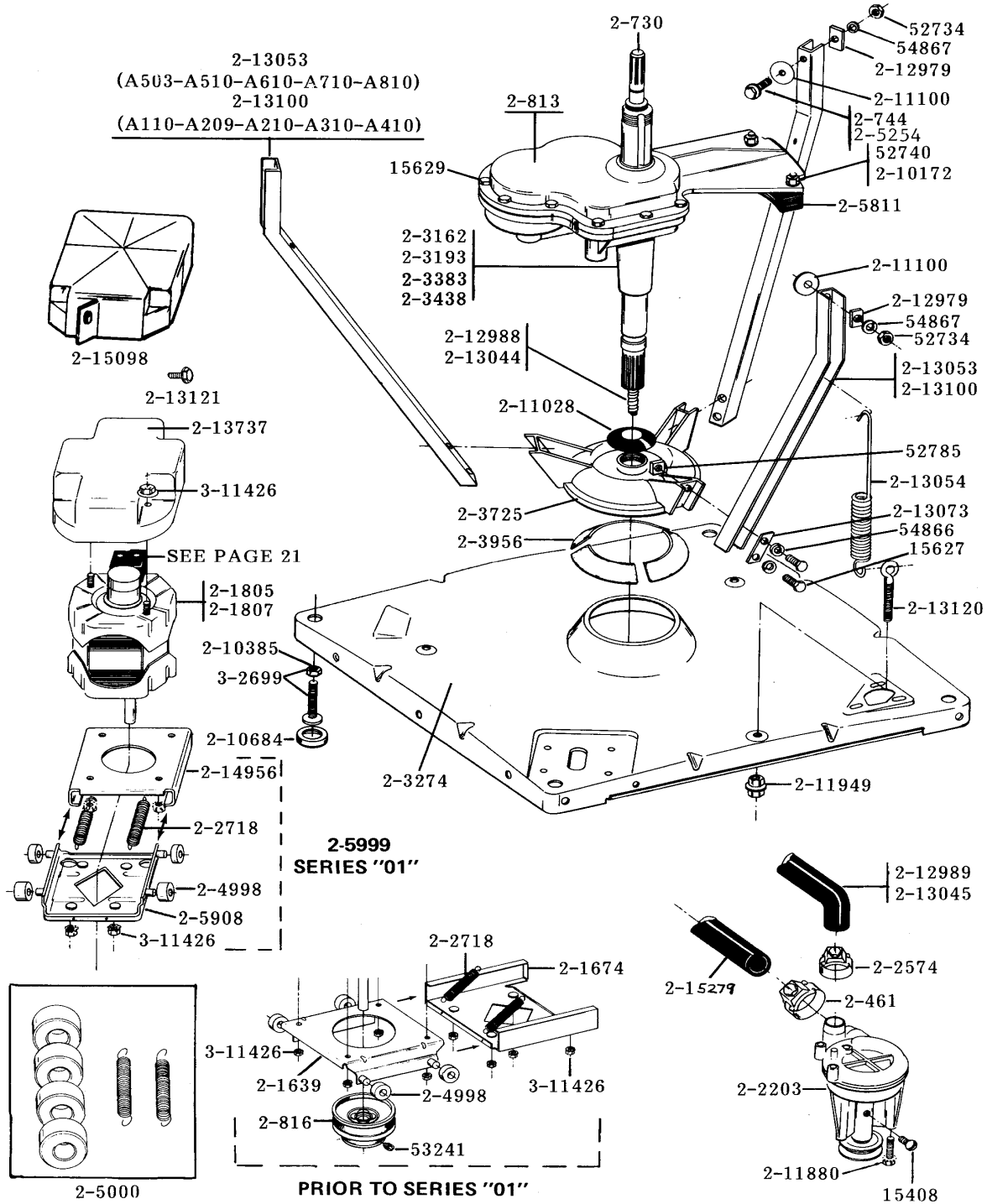

2-5999
SERIES "01"

PRIOR TO SERIES "01"

Section: BASE, PUMP, MOTOR & COMPONENTS

No.	Part No.	Description	Series	Qty
1	Y015408	SCREW, BEARING INSERT	00	1
2	Y015627	SCREW, HEX HD CAP 5/16 X 5/8	00	1
3	Y015629	BOLT, GRINDING CHAMBER-DRAI Note: BOLT, GRINDING CHAMBER	00	1
4	Y052734	NUT Note: NUT, BRACE TO TUB	00	1
5	Y052740	NUT	00	1
6	Y052785	NUT,BRACE TO DAMPER Note: NUT, BRACE TO DAMPER	00	1
7	Y053241	SET SCREW, PULLEY	00	1
8	N Y054866	LOCK WASHER Note: WASHER, LOCK	00	1
9	Y054867	WASHER, LOCK	00	1
10	200461	HOSE CLAMP - 1-5/8 INCH Note: CLAMP, HOSE 1-5/8 INCH	00	1
11	200730	AGITATOR SHAFT Note: SHAFT, AGITATOR	00	1
12	200744	BOLT & GASKET ASSY.(SHORT) Note: BOLT & GASKET ASSM.(SHORT)	00	1
13	N 200750	GEAR CASE COVER Note: COVER, GEAR CASE	00	1
14	N 200813	GEAR CASE COVER ASSEMBLY	00	1
15	200816	PULLEY, MOTOR (W/SET SCREW)	00	1
16	201639	UPPER MOTOR MOUNT Note: MOUNT, UPPER MOTOR	00	1
17	N 201674	LOWER MOTOR MOUNT----NA Note: MOUNT, LOWER MOTOR	00	1
18	201805	MOTOR (ONE SPEED)	00	1
19	202203	PUMP AS PAK	00	1
20	202574	CLAMP, HOSE	00	1
22	202718	TENSION SPRINGS Note: SPRINGS, TENSION	00	1
23	N 203162	GEAR HOUSING W/STUDS & TUBE	00	1
25	203274	BASE WITH DAMPER PADS	00	1
26	203723	POWER UNIT W/GEARS	00	1
27	203725	DAMPER W/BOLT & CLIP	00	1
28	203956	DAMPER PAD KIT (W/POLY LUBE)	00	1
29	204437	POWER UNIT WITH FAST GEARS	00	1
30	204807	GRND.WIRE,SUPP.PLTE TO TOP CVR Note: WIRE, GROUND	00	1
31	204998	GLIDE KIT (4 W/POLY LUBE)	00	1
32	205000	GLIDE & SPRING KIT	00	1
33	205131	SWITCH, MOTOR START	00	1
34	205132	SWITCH, MOTOR START	00	1
35	N 205133	MOTOR EXTERNAL START SWITCH Note: SWITCH, MOTOR EXTERNAL START	00	1
36	N 205134	MOTOR EXTERNAL START SWITCH Note: SWITCH, MOTOR EXTERNAL START	00	1
37	N 205811	COUNTERWEIGHT	00	1
38	205908	LOWER MOTOR MOUNT Note: MOUNT, LOWER MOTOR	01	1
39	205999	MOTOR MOUNT ASSM COMPLETE Note: MOTOR MOUNT ASSEMBLY	01	1
40	N 210172	LOCK WASHER Note: WASHER, LOCK	00	1
41	210385	NUT, LOCK	00	1
42	210684	FOOT, RUBBER	00	1
43	211028	DEFLECTOR,WATER (DRIVE TUBE) Note: DEFLECTOR, WATER (DRIVE TUBE)	00	1
44	211100	WASHER, CUSHION	00	1
45	211880	SCREW, HEX HD #10 X 1/2 INC	00	1
46	211949	NUT, EYEBOLT	00	1
47	212979	WASHER, TUB BRACE	00	1
48	212988	CENTER SHAFT Note: SHAFT, CENTER	00	1
49	Y212989	HOSE, OUTER TUB TO PUMP	00	1
53	213054	CENTERING SPRING - 3 USED Note: SPRING, CENTERING	00	1
54	213073	WASHER, DOUBLE Note: WASHER, DOUBLE BRACE	00	1
55	213100	BRACE, TUB	00	1
56	213120	EYE BOLT FOR CENTER SPRING Note: EYE BOLT, CENTER SPRING	00	1
57	213121	SCREW	00	1
58	213737	MOTOR SHIELD - POLY Note: SHIELD, MOTOR POLY	00	1
59	215279	HOSE, DRAIN	00	1
60	214956	MOUNT, MOTOR/UPPER Note: PLATE, UPPER MOTOR MOUNT	01	1
61	215098	SHIELD, MOTOR	00	1

*Color Code (-)=Not Shown #=Series, Serial Prefix or Run No., N=Not Available

Section: BASE, PUMP, MOTOR & COMPONENTS

Model: A209

ALL MODELS

BASE, PUMP, MOTOR & COMPONENTS

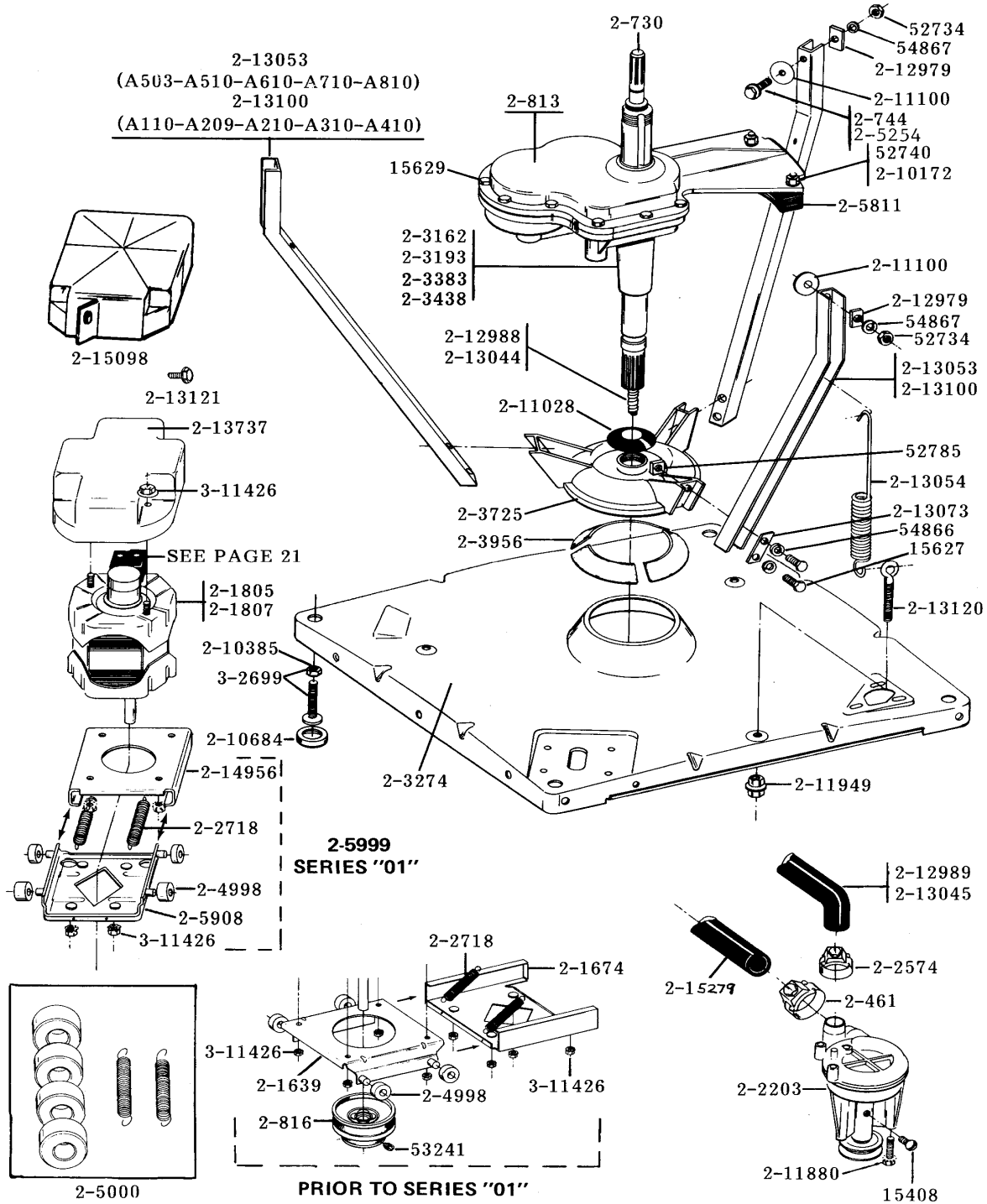

MA58B7

Section: BASE, PUMP, MOTOR & COMPONENTS

No.	Part No.	Description	Series	Qty
62	302699	LEG, ADJUSTABLE (W/NUT)	00	1
63	311426	NUT, WASHERED LOCK Note: KEPS NUT, MOTOR BASE	00	1

*Color Code (-)=Not Shown #=Series, Serial Prefix or Run No., N=Not Available

Section: CLUTCH, BRAKE & BELTS

Model: A209

ALL MODELS

CLUTCH, BRAKE & BELTS

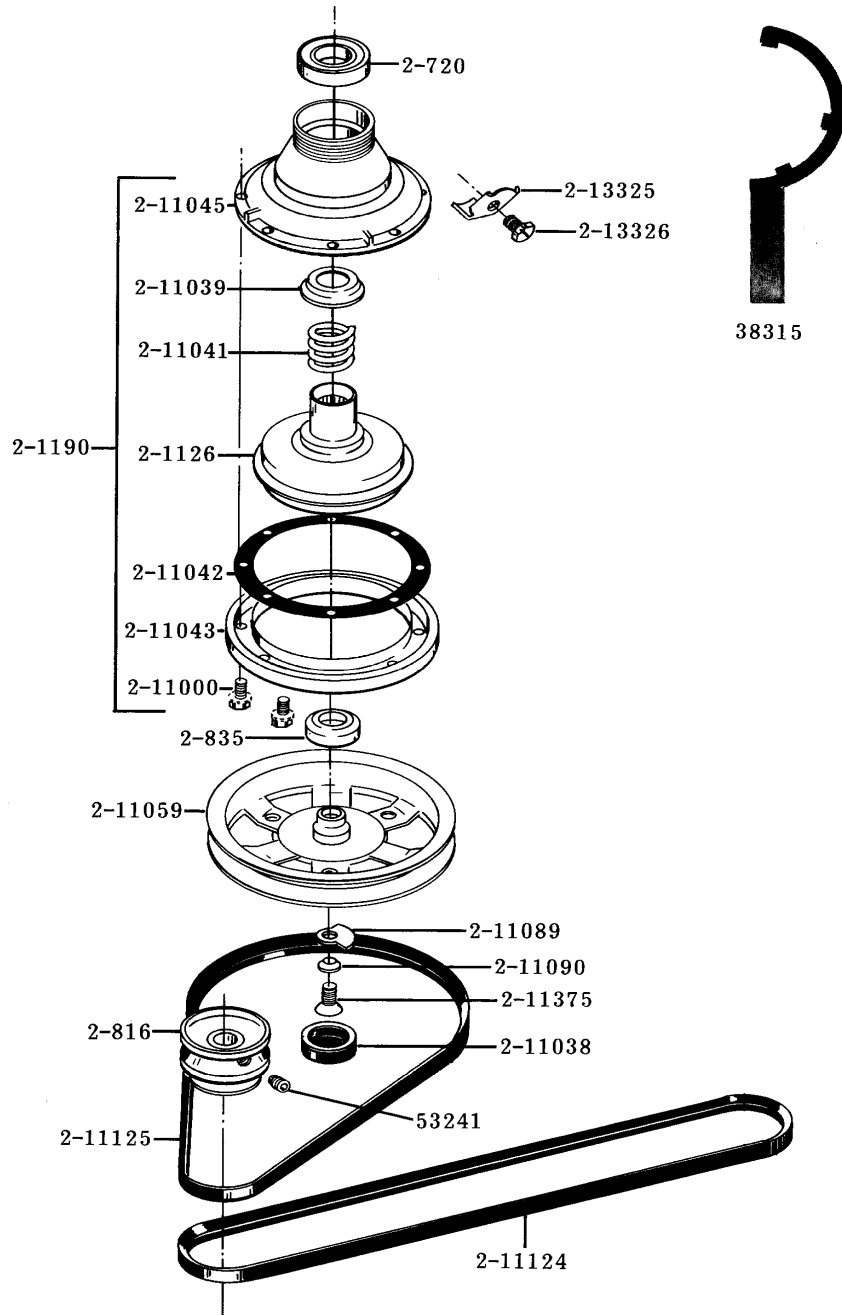

38315

4885

22

MA58B9

Section: CLUTCH, BRAKE & BELTS

No.	Part No.	Description	Series	Qty
1	Y038315	TOOL, BRAKE PKG ASSY Note: TOOL, BRAKE PACKAGE	00	1
2	Y053241	SET SCREW, PULLEY	00	1
3	200720	BALL BEARING, RADIAL	00	1
4	200816	PULLEY, MOTOR (W/SET SCREW)	00	1
5	200835	BEARING, BRAKE ROTOR	00	1
6	201126	ROTOR, BRAKE (W/FACING)	00	1
7	201190	BRAKE ASSEMBLY	00	1
8	211000	SCREW,HEX HEAD (BRAKE DRUM)	00	1
9	N 211038	CAP, OIL RETAINER	00	1
10	211039	RETAINER, BRAKE SPRING	00	1
11	211041	SPRING, BRAKE	00	1
12	211042	GASKET, BRAKE DRUM	00	1
13	211043	DRUM, BRAKE	00	1
14	211045	HOUSING, BRAKE	00	1
15	211059	PULLEY, DRIVE	00	1
16	211089	LUG, STOP	00	1
17	211090	WASHER, LOCK	00	1
18	211124	V BELT, PUMP	00	1
19	211125	V BELT,DRIVE PULLEY Note: V BELT, DRIVE PULLEY	00	1
20	211375	SCREW,STOP LUG(CENTER SHAFT) Note: SCREW, STOP LUG(CENTER SHAFT)	00	1
21	213325	CLIP, RETAINER	00	1
22	213326	SCREW, RETAINING CLIP Note: BOLT, RETAINING CLIP	00	1

*Color Code (-)=Not Shown #=Series, Serial Prefix or Run No., N=Not Available

